

CURRENT SENSOR

PRODUCT SERIES: SFG-P

SFG-0.3P/N, SFG-0.6P/N, SFG-1.0P/N
SFG-1.5P/N, SFG-2.0P/N, SFG-3.0P/N

PRODUCT PART NUMBER:

SFG-0.3P/P1, SFG-0.6P/P1, SFG-1.0P/P1
SFG-1.5P/P1, SFG-2.0P/P1, SFG-3.0P/P1
SFG-0.3P/P2, SFG-0.6P/P2, SFG-1.0P/P2
SFG-1.5P/P2, SFG-2.0P/P2, SFG-3.0P/P2

Version: Ver4.8

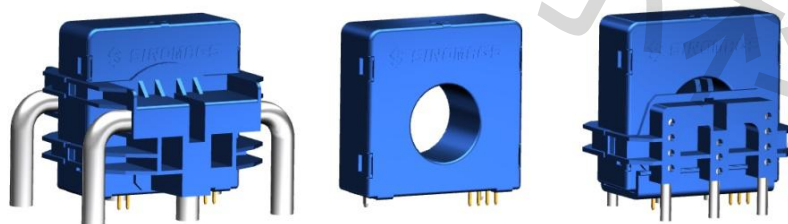

CONTENT

1.	Description.....	2
2.	Absolute parameter: SFG-P/N.....	3
3.	Absolute parameter: SFG-P/P1.....	4
4.	Absolute parameter: SFG-P/P2.....	5
5.	Electrical data: SFG-0.3P/N.....	6
6.	Electrical data: SFG-0.6P/N.....	7
7.	Electrical data: SFG-1.0P/N.....	8
8.	Electrical data: SFG-1.5P/N.....	9
9.	Electrical data: SFG-2.0P/N.....	10
10.	Electrical data: SFG-3.0P/N.....	11
11.	Electrical data: SFG-0.3P/P1.....	12
12.	Electrical data: SFG-0.6P/P1.....	13
13.	Electrical data: SFG-1.0P/P1.....	14
14.	Electrical data: SFG-1.5P/P1.....	15
15.	Electrical data: SFG-2.0P/P1.....	16
16.	Electrical data: SFG-3.0P/P1.....	17
17.	Electrical data: SFG-0.3P/P2.....	18
18.	Electrical data: SFG-0.6P/P2.....	19
19.	Electrical data: SFG-1.0P/P2.....	20
20.	Electrical data: SFG-1.5P/P2.....	21
21.	Electrical data: SFG-2.0P/P2.....	22
22.	Electrical data: SFG-3.0P/P2.....	23
23.	Connection.....	24
24.	SFG- P/N PCB footprint.....	24
25.	SFG- P/P1 PCB footprint.....	25
26.	SFG- P/P2 PCB footprint.....	26
27.	SFG- P/N Dimensions.....	27
28.	SFG- P/P1 Dimensions.....	28
29.	SFG- P/P2 Dimensions.....	29

1. Description

Features

- Closed loop (compensated) current transducer
- Voltage output
- Insulation voltage for 5 kVAC
- Single supply voltage
- PCB mounting.

Advantages

- High accuracy
- High overload capability
- High insulation capability
- High separation ability
- Low temperature drift
- Degauss and test functions

Applications

- Residual current measurement
- Leakage current measurement in PV inverters
- First human contact protection of PV arrays
- Failure detection in power sources
- Leakage current detection in stacked DC sources
- Communication power



Type Approved
Safety
Regular Production
Surveillance

www.tuv.com
ID 1419065811

2. Absolute parameter: SFG-P/N

Absolute maximum ratings

Parameter	Symbol	Unit	Value
Maximum Supply voltage	$V_{C \max}$	V	7
Maximum Primary conductor temperature	$T_{B \max}$	°C	110
Maximum overload capability (100 μ s, 500 A/ μ s)	$\hat{I}_{P \max}$	A	3300

Ratings

Parameter	Symbol	Unit	Value
Primary involved potential		V AC/DC	600
Max surrounding air temperature	T_A	°C	105
Secondary supply voltage	U_C	V DC	5
Output voltage	V_{out}	V	0 to 5

Isolation parameters

Parameter	Symbol	Unit	Value	Remark
RMS voltage for AC test 50 Hz/1 min	V_d	kV	5	
Impulse withstand voltage 1.2/50 μ s	V_w	kV	10.1	
Clearance distance (pri. –sec.)	d_{Cl}	mm	11	Shortest distance through air
Creepage distance (pri. –sec.)	d_{Cp}	mm	11	Shortest path along device body
Comparative tracking index	CTI	V	600	
Application example	-	V	600	Reinforced insulation, CAT III, PD2 non uniform field
Application example	-	V	1000	Basic insulation, CAT III, PD2 non uniform field

Environmental and mechanical characteristics

Parameter	Symbol	Unit	Min	Typ	Max	Comment
Ambient operating temperature	T_A	°C	-40		105	
Ambient storage temperature	T_S	°C	-40		105	
Mass	m	g		50		
standard	EN 50178, IEC 61010, UL 508					

3. Absolute parameter: SFG-P/P1

Absolute maximum ratings

Parameter	Symbol	Unit	Value
Maximum Supply voltage	$V_{C \max}$	V	7
Maximum Primary conductor temperature	$T_{B \max}$	°C	110
Maximum overload capability (100 μ s, 500 A/ μ s)	$\hat{I}_{P \max}$	A	3300
Maximum Voltage between test winding and secondary pins	$V_{d \max}$	V	35
Maximum Current of test winding	$I_{T \max}$	mA	300

Ratings

Parameter	Symbol	Unit	Value
Primary involved potential		V AC/DC	1000
Max surrounding air temperature	T_A	°C	105
Secondary supply voltage	U_C	V DC	5
Output voltage	V_{out}	V	0 to 5

Isolation parameters

Parameter	Symbol	Unit	Value	Remark
RMS voltage for AC	V_d	kV	4	test 50 Hz/1 min
Impulse withstand voltage	V_w	kV	10.1	1.2/50 μ s
Clearance distance (pri. –pri.)	d_{Cl}	mm	9.4	Shortest distance through air
Creepage distance (pri. – pri.)	d_{Cp}	mm	12.9	Shortest path along device body
Clearance distance (pri. –sec.)	d_{Cl}	mm	9.4	When mounted on PCB with recommended layout
Creepage distance (pri. –sec.)	d_{Cp}	mm	12.4	When mounted on PCB with recommended layout
Comparative tracking index	CTI	V	600	
Application example		V	600 CAT III, PD2	Reinforced insulation, non uniform field
Application example		V	1500 CAT III, PD2	Basic insulation, non uniform field

Environmental and mechanical characteristics

Parameter	Symbol	Unit	Min	Typ	Max	Comment
Ambient operating temperature	T_A	°C	-40		105	
Ambient storage temperature	T_S	°C	-40		105	
Mass	m	g		150		
standard	EN 50178, IEC 61010, UL 508					

4. Absolute parameter: SFG-P/P2

Absolute maximum ratings

Parameter	Symbol	Unit	Value
Maximum Supply voltage	$V_{C \max}$	V	7
Maximum Primary conductor temperature	$T_{B \max}$	°C	110
Maximum overload capability (100 μ s, 500 A/ μ s)	$\hat{I}_{P \max}$	A	3300

Ratings

Parameter	Symbol	Unit	Value
Primary involved potential		V AC/DC	1000
Max surrounding air temperature	T_A	°C	105
Secondary supply voltage	U_C	V DC	5
Output voltage	V_{out}	V	0 to 5

Isolation parameters

Parameter	Symbol	Unit	Value	Remark
RMS voltage for AC test 50Hz/1 min	V_d	kV	4	
Impulse withstand voltage 1.2/50 μ s	V_w	kV	10.1	
Clearance distance (pri. –pri.)	d_{Cl}	mm	11.4	Shortest distance through air
Creepage distance (pri. – pri.)	d_{Cp}	mm	15.8	Shortest path along device body
Clearance distance (pri. –sec.)	d_{Cl}	mm	10.6	Shortest distance through air
Creepage distance (pri. –sec.)	d_{Cp}	mm	13.3	Shortest path along device body
Comparative tracking index	CTI	V	600	
Application example	-	V	600 CAT III, PD2	Reinforced insulation, non uniform field
Application example	-	V	1000 CAT III, PD2	Basic insulation, non uniform field

Environmental and mechanical characteristics

Parameter	Symbol	Unit	Min	Typ	Max	Comment
Ambient operating temperature	T_A	°C	-40		105	
Ambient storage temperature	T_S	°C	-40		105	
Mass	m	g		80		
standard	EN 50178, IEC 61010, UL 508					

5. Electrical data: SFG-0.3P/N

At $T_A = 25\text{ }^\circ\text{C}$, $V_C = 5\text{ V}$.

Parameters	Symbol	Unit	Min	Typ	Max	Remark
Primary nominal residual rms current	I_{PN}	A		0.3		
Primary residual current, measuring range	I_{PM}	A	-0.5		0.5	
Supply voltage	V_C	V	4.75	5	5.25	
Current consumption	I_C	mA		17.5	21.6	$I_P(\text{mA}) / N_a$ $N_a = 1000\text{ turns}$ -40°C ...105°C
Output voltage referred to V_{ref} (Test current)	V_{out}	V	0.7	1.2	1.7	
Reference voltage @ $I_P = 0$	V_{ref}	V	2.495	2.5	2.505	Internal reference
External reference voltage	V_{REF}	V	2.3		4	Internal reference of V_{ref} input = 499 Ω
Electrical offset current referred to primary	I_{OE}	mA	-24	7	24	
Temperature coefficient of VOE @ $I_P = 0$	TCV_{OE}	ppm/K			± 570	ppm/K of 2.5 V -40 ... 105 °C
Theoretical sensitivity	G_{th}	V/A		4		
Sensitivity error	ϵ_G	%	-1.6	0.5	1.6	$R_L > 500\text{ k}\Omega$
Temperature coefficient of G	TCG	ppm/K			± 400	-40°C ...105°C
Linearity error	ϵ_L	%		0.5	1	
Reaction time @ 10 % of I_{PRN}	t_{ra}	μs		7		$R_L > 500\text{ k}\Omega$, $di/dt > 5\text{ A}/\mu\text{s}$
Step response time to 90 % of I_{PN}	t_r	μs		50		$R_L > 500\text{ k}\Omega$, $di/dt > 5\text{ A}/\mu\text{s}$
Frequency bandwidth (-3dB)	BW	kHz		15		$R_L > 500\text{ k}\Omega$
Noise(1 Hz ~ 10 kHz)	V_{no}	mV rms		10		$R_L > 500\text{ k}\Omega$
Accuracy@ I_{PN} @TA = 25°C	X_{25c}	% of I_{PN}		± 1.9		
Accuracy@ I_{PN} @TA = 105°C	X_{105c}	% of I_{PN}		± 3.2		

6. Electrical data: SFG-0.6P/N

At $T_A = 25\text{ }^\circ\text{C}$, $V_C = 5\text{ V}$.

Parameters	Symbol	Unit	Min	Typ	Max	Remark
Primary nominal residual rms current	I_{PN}	A		0.6		
Primary residual current, measuring range	I_{PM}	A	-0.85		0.85	
Supply voltage	V_C	V	4.75	5	5.25	
Current consumption	I_C	mA		17.5	21.6	$I_P(\text{mA}) / N_a$ $N_a = 1000\text{ turns}$ -40°C ...105°C
Output voltage referred to V_{ref} (Test current)	V_{out}	V	0.4	0.75	1.1	
Reference voltage @ $I_P = 0$	V_{ref}	V	2.495	2.5	2.505	Internal reference
External reference voltage	V_{REF}	V	2.3		4	Internal reference of V_{ref} input = 499 Ω
Electrical offset current referred to primary	I_{OE}	mA	-24	4.2	24	
Temperature coefficient of VOE @ $I_P = 0$	TCV_{OE}	ppm/K			± 520	ppm/K of 2.5 V -40 ... 105 °C
Theoretical sensitivity	G_{th}	V/A		2.476		
Sensitivity error	ϵ_G	%	-0.7	0.5	0.7	$R_L > 500\text{ k}\Omega$
Temperature coefficient of G	TCG	ppm/K			± 100	-40°C ...105°C
Linearity error	ϵ_L	%		0.4	1.3	
Reaction time @ 10 % of I_{PRN}	t_{ra}	μs		5		$R_L > 500\text{ k}\Omega$, $di/dt > 5\text{ A}/\mu\text{s}$
Step response time to 90 % of I_{PN}	t_r	μs		30		$R_L > 500\text{ k}\Omega$, $di/dt > 5\text{ A}/\mu\text{s}$
Frequency bandwidth (-3dB)	BW	kHz		15		$R_L > 500\text{ k}\Omega$
Noise(1 Hz ~ 10 kHz)	V_{no}	mV rms		10		$R_L > 500\text{ k}\Omega$
Accuracy@ I_{PN} @TA = 25°C	X_{25c}	% of I_{PN}		± 1.9		
Accuracy@ I_{PN} @TA = 105°C	X_{105c}	% of I_{PN}		± 3.2		

7. Electrical data: SFG-1.0P/N

At $T_A = 25\text{ }^\circ\text{C}$, $V_C = 5\text{ V}$.

Parameters	Symbol	Unit	Min	Typ	Max	Remark
Primary nominal residual rms current	I_{PN}	A		1		
Primary residual current, measuring range	I_{PM}	A	-1.7		1.7	
Supply voltage	V_C	V	4.75	5	5.25	
Current consumption	I_C	mA		17.5	21.6	$I_P(\text{mA}) / N_a$ $N_a = 1000\text{ turns}$ -40°C ...105°C
Output voltage referred to V_{ref} (Test current)	V_{out}	V	0.2	0.35	0.5	
Reference voltage @ $I_P = 0$	V_{ref}	V	2.495	2.5	2.505	Internal reference
External reference voltage	V_{REF}	V	2.3		4	Internal reference of V_{ref} input = 499 Ω
Electrical offset current referred to primary	I_{OE}	mA	-24	7	24	
Temperature coefficient of VOE @ $I_P = 0$	TCV_{OE}	ppm/K		± 50	± 500	ppm/K of 2.5 V -40 ... 105 °C
Theoretical sensitivity	G_{th}	V/A		1.2		
Sensitivity error	ϵ_G	%	-1.6	0.5	1.6	$R_L > 500\text{ k}\Omega$
Temperature coefficient of G	TCG	ppm/K			± 400	-40°C ...105°C
Linearity error	ϵ_L	%		0.5	1	
Reaction time @ 10 % of I_{PRN}	t_{ra}	μs		7		$R_L > 500\text{ k}\Omega$, $di/dt > 5\text{ A}/\mu\text{s}$
Step response time to 90 % of I_{PN}	t_r	μs		50		$R_L > 500\text{ k}\Omega$, $di/dt > 5\text{ A}/\mu\text{s}$
Frequency bandwidth (-3dB)	BW	kHz		15		$R_L > 500\text{ k}\Omega$
Noise(1 Hz ~ 10 kHz)	V_{no}	mV rms		10		$R_L > 500\text{ k}\Omega$
Accuracy@ I_{PN} @TA = 25°C	X_{25c}	% of I_{PN}		± 1.9		
Accuracy@ I_{PN} @TA = 105°C	X_{105c}	% of I_{PN}		± 3.2		

8. Electrical data: SFG-1.5P/N

At $T_A = 25\text{ }^\circ\text{C}$, $V_C = 5\text{ V}$.

Parameters	Symbol	Unit	Min	Typ	Max	Remark
Primary nominal residual rms current	I_{PN}	A		1.5		
Primary residual current, measuring range	I_{PM}	A	-2		2	
Supply voltage	V_C	V	4.75	5	5.5	
Current consumption	I_C	mA		17.5	21.6	$I_P(\text{mA}) / N_a$ $N_a = 1000\text{ turns}$ - $40\text{ }^\circ\text{C} \dots 105\text{ }^\circ\text{C}$
Output voltage referred to V_{ref} (Test current)	V_{out}	V	0.12		0.5	
Reference voltage @ $I_P = 0$	V_{ref}	V	2.495	2.5	2.505	Internal reference
External reference voltage	V_{REF}	V	2.3		4	Internal reference of V_{ref} input = $499\ \Omega$
Electrical offset current referred to primary	I_{OE}	mA	-30	4.2	30	
Temperature coefficient of VOE @ $I_P = 0$	TCV_{OE}	ppm/K			± 570	ppm/K of 2.5 V - $40 \dots 105\text{ }^\circ\text{C}$
Theoretical sensitivity	G_{th}	V/A		0.8		
Sensitivity error	ϵ_G	%	-1.6	0.5	1.6	$R_L > 500\text{ k}\Omega$
Temperature coefficient of G	TCG	ppm/K			± 400	- $40\text{ }^\circ\text{C} \dots 105\text{ }^\circ\text{C}$
Linearity error	ϵ_L	%		0.5	1	
Reaction time @ 10 % of I_{PRN}	t_{ra}	μs		5		$R_L > 500\text{ k}\Omega$, $di/dt > 5\text{ A}/\mu\text{s}$
Step response time to 90 % of I_{PN}	t_r	μs		50		$R_L > 500\text{ k}\Omega$, $di/dt > 5\text{ A}/\mu\text{s}$
Frequency bandwidth (-3dB)	BW	kHz		15		$R_L > 500\text{ k}\Omega$
Noise(1 Hz ~ 10 kHz)	V_{no}	mV rms		10		$R_L > 500\text{ k}\Omega$
Accuracy@ I_{PN} @ $T_A = 25\text{ }^\circ\text{C}$	X_{25c}	% of I_{PN}		± 1.9		
Accuracy@ I_{PN} @ $T_A = 105\text{ }^\circ\text{C}$	X_{105c}	% of I_{PN}		± 3.2		

9. Electrical data: SFG-2.0P/N

At $T_A = 25\text{ }^\circ\text{C}$, $V_C = 5\text{ V}$.

Parameters	Symbol	Unit	Min	Typ	Max	Remark
Primary nominal residual rms current	I_{PN}	A		2.0		
Primary residual current, measuring range	I_{PM}	A	-3.0		3.0	
Supply voltage	V_C	V	4.75	5	5.5	
Current consumption	I_C	mA		17.5	21.6	$I_P(\text{mA}) / N_a$ $N_a = 1000$ turns - $40\text{ }^\circ\text{C} \dots 105\text{ }^\circ\text{C}$
Reference voltage @ $I_P = 0$	V_{ref}	V	2.495	2.5	2.505	Internal reference
External reference voltage	V_{REF}	V	2.3		4	Internal reference of V_{ref} input = $499\ \Omega$
Electrical offset current referred to primary	I_{OE}	mA	-24	7	24	
Temperature coefficient of VOE @ $I_P = 0$	TCV_{OE}	ppm/K			± 570	ppm/K of 2.5 V - $40 \dots 105\text{ }^\circ\text{C}$
Theoretical sensitivity	G_{th}	V/A		0.66		
Sensitivity error	ϵ_G	%	-1.6	0.5	1.6	$R_L > 500\text{ k}\Omega$
Temperature coefficient of G	TCG	ppm/K			± 400	- $40\text{ }^\circ\text{C} \dots 105\text{ }^\circ\text{C}$
Linearity error	ϵ_L	%		0.5	1	
Reaction time @ 10 % of I_{PRN}	t_{ra}	μs		5		$R_L > 500\text{ k}\Omega$, $di/dt > 5\text{ A}/\mu\text{s}$
Step response time to 90 % of I_{PN}	t_r	μs		50		$R_L > 500\text{ k}\Omega$, $di/dt > 5\text{ A}/\mu\text{s}$
Frequency bandwidth (-3dB)	BW	kHz		15		$R_L > 500\text{ k}\Omega$
Noise(1 Hz ~ 10 kHz)	V_{no}	mV rms		5		$R_L > 500\text{ k}\Omega$
Accuracy@ I_{PN} @ $T_A = 25\text{ }^\circ\text{C}$	$X_{25\text{ }^\circ\text{C}}$	% of I_{PN}		± 1.9		
Accuracy@ I_{PN} @ $T_A = 105\text{ }^\circ\text{C}$	$X_{105\text{ }^\circ\text{C}}$	% of I_{PN}		± 3.2		

10. Electrical data: SFG-3.0P/N

At $T_A = 25\text{ }^\circ\text{C}$, $V_C = 5\text{ V}$.

Parameters	Symbol	Unit	Min	Typ	Max	Remark
Primary nominal residual rms current	I_{PN}	A		3.0		
Primary residual current, measuring range	I_{PM}	A	-5		5	
Supply voltage	V_C	V	4.75	5	5.5	
Current consumption	I_C	mA		17.5	21.6	$I_P(\text{mA}) / N_a$ $N_a = 1000$ turns - $40\text{ }^\circ\text{C} \dots 105\text{ }^\circ\text{C}$
Reference voltage @ $I_P = 0$	V_{ref}	V	2.495	2.5	2.505	Internal reference
External reference voltage	V_{REF}	V	2.3		4	Internal reference of V_{ref} input = $499\ \Omega$
Electrical offset current referred to primary	I_{OE}	mA	-24	7	24	
Temperature coefficient of VOE @ $I_P = 0$	TCV_{OE}	ppm/K			± 570	ppm/K of 2.5 V - $40 \dots 105\text{ }^\circ\text{C}$
Theoretical sensitivity	G_{th}	V/A		0.4		
Sensitivity error	ϵ_G	%	-1.6	0.5	1.6	$R_L > 500\text{ k}\Omega$
Temperature coefficient of G	TCG	ppm/K			± 400	- $40\text{ }^\circ\text{C} \dots 105\text{ }^\circ\text{C}$
Linearity error	ϵ_L	%		0.5	1	
Reaction time @ 10 % of I_{PRN}	t_{ra}	μs		5		$R_L > 500\text{ k}\Omega$, $di/dt > 5\text{ A}/\mu\text{s}$
Step response time to 90 % of I_{PN}	t_r	μs		50		$R_L > 500\text{ k}\Omega$, $di/dt > 5\text{ A}/\mu\text{s}$
Frequency bandwidth (-3dB)	BW	kHz		15		$R_L > 500\text{ k}\Omega$
Noise(1 Hz ~ 10 kHz)	V_{no}	mV rms		10		$R_L > 500\text{ k}\Omega$
Accuracy@ I_{PN} @ $T_A = 25\text{ }^\circ\text{C}$	$X_{25\text{ }^\circ\text{C}}$	% of I_{PN}		± 1.9		
Accuracy@ I_{PN} @ $T_A = 105\text{ }^\circ\text{C}$	$X_{105\text{ }^\circ\text{C}}$	% of I_{PN}		± 3.2		

11. Electrical data: SFG-0.3P/P1

At $T_A = 25\text{ }^\circ\text{C}$, $V_C = 5\text{ V}$.

Parameters	Symbol	Unit	Min	Typ	Max	Remark
Primary nominal residual rms current	I_{PN}	A		0.3		
Primary residual current, measuring range	I_{PM}	A	-0.5		0.5	
Supply voltage	V_C	V	4.75	5	5.25	
Current consumption	I_C	mA		17.5	21.6	$I_P(\text{mA}) / N_a$ $N_a = 1000\text{ turns}$ -40°C ...105°C
Output voltage referred to V_{ref} (Test current)	V_{out}	V	0.7	1.2	1.7	
Reference voltage @ $I_P = 0$	V_{ref}	V	2.495	2.5	2.505	Internal reference
External reference voltage	V_{REF}	V	2.3		4	Internal reference of V_{ref} input = 499 Ω
Electrical offset current referred to primary	I_{OE}	mA	-24	7	24	
Temperature coefficient of VOE @ $I_P = 0$	TCV_{OE}	ppm/K			± 570	ppm/K of 2.5 V -40 ... 105 °C
Theoretical sensitivity	G_{th}	V/A		4		
Sensitivity error	ϵ_G	%	-1.6	0.5	1.6	$R_L > 500\text{ k}\Omega$
Temperature coefficient of G	TCG	ppm/K			± 400	-40°C ...105°C
Linearity error	ϵ_L	%		0.5	1	
Number of turns (test winding)	N_T			20		$R_L > 500\text{ k}\Omega$, $di/dt > 5\text{ A}/\mu\text{s}$
Reaction time @ 10 % of I_{PRN}	t_{ra}	μs		7		$R_L > 500\text{ k}\Omega$, $di/dt > 5\text{ A}/\mu\text{s}$
Step response time to 90 % of I_{PN}	t_r	μs		50		$R_L > 500\text{ k}\Omega$, $di/dt > 5\text{ A}/\mu\text{s}$
Frequency bandwidth (-3dB)	BW	kHz		15		$R_L > 500\text{ k}\Omega$
Noise(1 Hz ~ 10 kHz)	V_{no}	mV rms		10		$R_L > 500\text{ k}\Omega$
Accuracy@ I_{PN} @TA = 25°C	$X_{25^\circ\text{C}}$	% of I_{PN}		± 1.9		
Accuracy@ I_{PN} @TA = 105°C	$X_{105^\circ\text{C}}$	% of I_{PN}		± 3.2		

12. Electrical data: SFG-0.6P/P1

At $T_A = 25\text{ }^\circ\text{C}$, $V_C = 5\text{ V}$.

Parameters	Symbol	Unit	Min	Typ	Max	Remark
Primary nominal residual rms current	I_{PN}	A		0.6		
Primary residual current, measuring range	I_{PM}	A	-0.85		0.85	
Supply voltage	V_C	V	4.75	5	5.25	
Current consumption	I_C	mA		17.5	21.6	$I_P(\text{mA}) / N_a$ $N_a = 1000$ turns - $40\text{ }^\circ\text{C} \dots 105\text{ }^\circ\text{C}$
Output voltage referred to V_{ref} (Test current)	V_{out}	V	0.4	0.75	1.1	
Reference voltage @ $I_P = 0$	V_{ref}	V	2.495	2.5	2.505	Internal reference
External reference voltage	V_{REF}	V	2.3		4	Internal reference of V_{ref} input = $499\ \Omega$
Electrical offset current referred to primary	I_{OE}	mA	-24	4.2	24	
Temperature coefficient of VOE @ $I_P = 0$	TCV_{OE}	ppm/K			± 520	ppm/K of 2.5 V - $40 \dots 105\text{ }^\circ\text{C}$
Theoretical sensitivity	G_{th}	V/A		2.476		
Sensitivity error	ϵ_G	%	-0.7	0.5	0.7	$R_L > 500\text{ k}\Omega$
Temperature coefficient of G	TCG	ppm/K			± 100	- $40\text{ }^\circ\text{C} \dots 105\text{ }^\circ\text{C}$
Linearity error	ϵ_L	%		0.4	1.3	
Number of turns (test winding)	N_T			20		$R_L > 500\text{ k}\Omega$, $di/dt > 5\text{ A}/\mu\text{s}$
Reaction time @ 10 % of I_{PRN}	t_{ra}	μs		5		$R_L > 500\text{ k}\Omega$, $di/dt > 5\text{ A}/\mu\text{s}$
Step response time to 90 % of I_{PN}	t_r	μs		40		$R_L > 500\text{ k}\Omega$
Frequency bandwidth (-3dB)	BW	kHz		15		$R_L > 500\text{ k}\Omega$
Noise(1 Hz ~ 10 kHz)	V_{no}	mV rms		10		
Accuracy@ I_{PN} @ $T_A = 25\text{ }^\circ\text{C}$	$X_{25\text{C}}$	% of I_{PN}		± 1.9		
Accuracy@ I_{PN} @ $T_A = 105\text{ }^\circ\text{C}$	$X_{105\text{C}}$	% of I_{PN}		± 3.2		

13. Electrical data: SFG-1.0P/P1

At $T_A = 25\text{ }^\circ\text{C}$, $V_C = 5\text{ V}$.

Parameters	Symbol	Unit	Min	Typ	Max	Remark
Primary nominal residual rms current	I_{PN}	A		1		
Primary residual current, measuring range	I_{PM}	A	-1.7		1.7	
Supply voltage	V_C	V	4.75	5	5.25	
Current consumption	I_C	mA		17.5	21.6	$I_P(\text{mA}) / N_a$ $N_a = 1000$ turns - $40\text{ }^\circ\text{C} \dots 105\text{ }^\circ\text{C}$
Output voltage referred to V_{ref} (Test current)	V_{out}	V	0.2	0.35	0.5	
Reference voltage @ $I_P = 0$	V_{ref}	V	2.495	2.5	2.505	Internal reference
External reference voltage	V_{REF}	V	2.3		4	Internal reference of V_{ref} input = $499\ \Omega$
Electrical offset current referred to primary	I_{OE}	mA	-24	7	24	
Temperature coefficient of VOE @ $I_P = 0$	TCV_{OE}	ppm/K		± 50	± 500	ppm/K of 2.5 V - $40 \dots 105\text{ }^\circ\text{C}$
Theoretical sensitivity	G_{th}	V/A		1.2		
Sensitivity error	ϵ_G	%	-1.6	0.5	1.6	$R_L > 500\text{ k}\Omega$
Temperature coefficient of G	TCG	ppm/K			± 400	- $40\text{ }^\circ\text{C} \dots 105\text{ }^\circ\text{C}$
Linearity error	ϵ_L	%		0.5	1	
Number of turns (test winding)	N_T			20		$R_L > 500\text{ k}\Omega$, $di/dt > 5\text{ A}/\mu\text{s}$
Reaction time @ 10 % of I_{PRN}	t_{ra}	μs		7		$R_L > 500\text{ k}\Omega$, $di/dt > 5\text{ A}/\mu\text{s}$
Step response time to 90 % of I_{PN}	t_r	μs		50		$R_L > 500\text{ k}\Omega$, $di/dt > 5\text{ A}/\mu\text{s}$
Frequency bandwidth (-3dB)	BW	kHz		15		$R_L > 500\text{ k}\Omega$
Noise(1 Hz ~ 10 kHz)	V_{no}	mV rms		10		$R_L > 500\text{ k}\Omega$
Accuracy@ I_{PN} @ $T_A = 25\text{ }^\circ\text{C}$	$X_{25\text{ }^\circ\text{C}}$	% of I_{PN}		± 1.9		
Accuracy@ I_{PN} @ $T_A = 105\text{ }^\circ\text{C}$	$X_{105\text{ }^\circ\text{C}}$	% of I_{PN}		± 3.2		

14. Electrical data: SFG-1.5P/P1

At $T_A = 25\text{ }^\circ\text{C}$, $V_C = 5\text{ V}$.

Parameters	Symbol	Unit	Min	Typ	Max	Remark
Primary nominal residual rms current	I_{PN}	A		1.5		
Primary residual current, measuring range	I_{PM}	A	-2		2	
Supply voltage	V_C	V	4.75	5	5.5	
Current consumption	I_C	mA		17.5	21.6	$I_P(\text{mA}) / N_a$ $N_a = 1000\text{ turns}$ - $40\text{ }^\circ\text{C} \dots 105\text{ }^\circ\text{C}$
Output voltage referred to V_{ref} (Test current)	V_{out}	V	0.12		0.5	
Reference voltage @ $I_P = 0$	V_{ref}	V	2.495	2.5	2.505	Internal reference
External reference voltage	V_{REF}	V	2.3		4	Internal reference of V_{ref} input = $499\ \Omega$
Electrical offset current referred to primary	I_{OE}	mA	-30	4.2	30	
Temperature coefficient of VOE @ $I_P = 0$	TCV_{OE}	ppm/K			± 570	ppm/K of 2.5 V - $40 \dots 105\text{ }^\circ\text{C}$
Theoretical sensitivity	G_{th}	V/A		0.8		
Sensitivity error	ϵ_G	%	-1.6	0.5	1.6	$R_L > 500\text{ k}\Omega$
Temperature coefficient of G	TCG	ppm/K			± 400	- $40\text{ }^\circ\text{C} \dots 105\text{ }^\circ\text{C}$
Linearity error	ϵ_L	%		0.5	1	
Number of turns (test winding)	N_T			20		$R_L > 500\text{ k}\Omega$, $di/dt > 5\text{ A}/\mu\text{s}$
Reaction time @ 10 % of I_{PRN}	t_{ra}	μs		5		$R_L > 500\text{ k}\Omega$, $di/dt > 5\text{ A}/\mu\text{s}$
Step response time to 90 % of I_{PN}	t_r	μs		50		$R_L > 500\text{ k}\Omega$, $di/dt > 5\text{ A}/\mu\text{s}$
Frequency bandwidth (-3dB)	BW	kHz		15		$R_L > 500\text{ k}\Omega$
Noise(1 Hz ~ 10 kHz)	V_{no}	mV rms		10		$R_L > 500\text{ k}\Omega$
Accuracy@ I_{PN} @ $T_A = 25\text{ }^\circ\text{C}$	X_{25c}	% of I_{PN}		± 1.9		
Accuracy@ I_{PN} @ $T_A = 105\text{ }^\circ\text{C}$	X_{105c}	% of I_{PN}		± 3.2		

15. Electrical data: SFG-2.0P/P1

At $T_A = 25\text{ }^\circ\text{C}$, $V_C = 5\text{ V}$.

Parameters	Symbol	Unit	Min	Typ	Max	Remark
Primary nominal residual rms current	I_{PN}	A		2		
Primary residual current, measuring range	I_{PM}	A	-3		3	
Supply voltage	V_C	V	4.75	5	5.5	
Current consumption	I_C	mA		17.5	21.6	$I_P(\text{mA}) / N_a$ $N_a = 1000$ turns - $40\text{ }^\circ\text{C} \dots 105\text{ }^\circ\text{C}$
Reference voltage @ $I_P = 0$	V_{ref}	V	2.495	2.5	2.505	Internal reference
External reference voltage	V_{REF}	V	2.3		4	Internal reference of V_{ref} input = $499\ \Omega$
Electrical offset current referred to primary	I_{OE}	mA	-24	7	24	
Temperature coefficient of VOE @ $I_P = 0$	TCV_{OE}	ppm/K			570	ppm/K of 2.5 V - $40 \dots 105\text{ }^\circ\text{C}$
Theoretical sensitivity	G_{th}	V/A		0.66		
Sensitivity error	ϵ_G	%	-1.6	0.5	1.6	$R_L > 500\text{ k}\Omega$
Temperature coefficient of G	TCG	ppm/K		± 400		- $40\text{ }^\circ\text{C} \dots 105\text{ }^\circ\text{C}$
Linearity error	ϵ_L	%		0.5	1	
Number of turns (test winding)	N_T			20		$R_L > 500\text{ k}\Omega$, $di/dt > 5\text{ A}/\mu\text{s}$
Reaction time @ 10 % of I_{PRN}	t_{ra}	μs		5		$R_L > 500\text{ k}\Omega$, $di/dt > 5\text{ A}/\mu\text{s}$
Step response time to 90 % of I_{PN}	t_r	μs		40		$R_L > 500\text{ k}\Omega$
Frequency bandwidth (-3dB)	BW	kHz		15		$R_L > 500\text{ k}\Omega$
Noise(1 Hz ~ 10 kHz)	V_{no}	mV rms		10		
Accuracy@ I_{PN} @ $T_A = 25\text{ }^\circ\text{C}$	X_{25c}	% of I_{PN}		± 1.9		
Accuracy@ I_{PN} @ $T_A = 105\text{ }^\circ\text{C}$	X_{105c}	% of I_{PN}		± 3.2		

16. Electrical data: SFG-3.0P/P1

At $T_A = 25\text{ }^\circ\text{C}$, $V_C = 5\text{ V}$.

Parameters	Symbol	Unit	Min	Typ	Max	Remark
Primary nominal residual rms current	I_{PN}	A		3		
Primary residual current, measuring range	I_{PM}	A	-5		5	
Supply voltage	V_C	V	4.75	5	5.5	
Current consumption	I_C	mA		17.5	21.6	$I_P(\text{mA}) / N_a$ $N_a = 1000$ turns - $40\text{ }^\circ\text{C} \dots 105\text{ }^\circ\text{C}$
Reference voltage @ $I_P = 0$	V_{ref}	V	2.495	2.5	2.505	Internal reference
External reference voltage	V_{REF}	V	2.3		4	Internal reference of V_{ref} input = $499\ \Omega$
Electrical offset current referred to primary	I_{OE}	mA	-24	7	24	
Temperature coefficient of VOE @ $I_P = 0$	TCV_{OE}	ppm/K			570	ppm/K of 2.5 V - $40 \dots 105\text{ }^\circ\text{C}$
Theoretical sensitivity	G_{th}	V/A		0.4		
Sensitivity error	ϵ_G	%	-1.6	0.5	1.6	$R_L > 500\text{ k}\Omega$
Temperature coefficient of G	TCG	ppm/K		± 400		- $40\text{ }^\circ\text{C} \dots 105\text{ }^\circ\text{C}$
Linearity error	ϵ_L	%		0.5	1	
Number of turns (test winding)	N_T			20		$R_L > 500\text{ k}\Omega$, $di/dt > 5\text{ A}/\mu\text{s}$
Reaction time @ 10 % of I_{PRN}	t_{ra}	μs		5		$R_L > 500\text{ k}\Omega$, $di/dt > 5\text{ A}/\mu\text{s}$
Step response time to 90 % of I_{PN}	t_r	μs		40		$R_L > 500\text{ k}\Omega$
Frequency bandwidth (-3dB)	BW	kHz		15		$R_L > 500\text{ k}\Omega$
Noise(1 Hz ~ 10 kHz)	V_{no}	mV rms		10		
Accuracy@ I_{PN} @ $T_A = 25\text{ }^\circ\text{C}$	X_{25c}	% of I_{PN}		± 1.9		
Accuracy@ I_{PN} @ $T_A = 105\text{ }^\circ\text{C}$	X_{105c}	% of I_{PN}		± 3.2		

17. Electrical data: SFG-0.3P/P2

At $T_A = 25\text{ }^\circ\text{C}$, $V_C = 5\text{ V}$.

Parameters	Symbol	Unit	Min	Typ	Max	Remark
Primary nominal residual rms current	I_{PN}	A		0.3		
Primary residual current, measuring range	I_{PM}	A	-0.5		0.5	
Supply voltage	V_C	V	4.75	5	5.25	
Current consumption	I_C	mA		17.5	21.6	$I_P(\text{mA}) / N_a$ $N_a = 1000$ turns - $40\text{ }^\circ\text{C} \dots 105\text{ }^\circ\text{C}$
Output voltage referred to V_{ref} (Test current)	V_{out}	V	0.7	1.2	1.7	
Reference voltage @ $I_P = 0$	V_{ref}	V	2.495	2.5	2.505	Internal reference
External reference voltage	V_{REF}	V	2.3		4	Internal reference of V_{ref} input = $499\ \Omega$
Electrical offset current referred to primary	I_{OE}	mA	-24	7	24	
Temperature coefficient of VOE @ $I_P = 0$	TCV_{OE}	ppm/K			± 570	ppm/K of 2.5 V - $40 \dots 105\text{ }^\circ\text{C}$
Theoretical sensitivity	G_{th}	V/A		4		
Sensitivity error	ϵ_G	%	-1.6	0.5	1.6	$R_L > 500\text{ k}\Omega$
Temperature coefficient of G	TCG	ppm/K			± 400	- $40\text{ }^\circ\text{C} \dots 105\text{ }^\circ\text{C}$
Linearity error	ϵ_L	%		0.5	1	
Check current	I_{CK}	mA		100		10%
Output voltage(Check function)	V_{CK}	V		$V_{OS}+0.4$		
Check enable voltage	V_{CE}	V	3.3		V_C	
Check disabled voltage	V_{CD}	V		< 0.2		
Reaction time @ 10 % of I_{PRN}	t_{ra}	μs		7		$R_L > 500\text{ k}\Omega$, $di/dt > 5\text{ A}/\mu\text{s}$
Step response time to 90 % of I_{PN}	t_r	μs		50		$R_L > 500\text{ k}\Omega$, $di/dt > 5\text{ A}/\mu\text{s}$
Frequency bandwidth (-3dB)	BW	kHz		15		$R_L > 500\text{ k}\Omega$
Noise(1 Hz ~ 10 kHz)	V_{no}	mV rms		10		$R_L > 500\text{ k}\Omega$
Accuracy@ I_{PN} @ $T_A = 25\text{ }^\circ\text{C}$	X_{25c}	% of I_{PN}		± 1.9		
Accuracy@ I_{PN} @ $T_A = 105\text{ }^\circ\text{C}$	X_{105c}	% of I_{PN}		± 3.2		

18. Electrical data: SFG-0.6P/P2

At $T_A = 25\text{ }^\circ\text{C}$, $V_C = 5\text{ V}$.

Parameters	Symbol	Unit	Min	Typ	Max	Remark
Primary nominal residual rms current	I_{PN}	A		0.6		
Primary residual current, measuring range	I_{PM}	A	-0.85		0.85	
Supply voltage	V_C	V	4.75	5	5.25	
Current consumption	I_C	mA		17.5	21.6	$I_P(\text{mA}) / N_a$ $N_a = 1000$ turns -40°C ...105°C
Output voltage referred to V_{ref} (Test current)	V_{out}	V	0.4	0.75	1.1	
Reference voltage @ $I_P = 0$	V_{ref}	V	2.495	2.5	2.505	Internal reference
External reference voltage	V_{REF}	V	2.3		4	Internal reference of V_{ref} input = 499Ω
Electrical offset current referred to primary	I_{OE}	mA	-24	4.2	24	
Temperature coefficient of VOE @ $I_P = 0$	TCV_{OE}	ppm/K			±520	ppm/K of 2.5 V -40 ... 105 °C
Theoretical sensitivity	G_{th}	V/A		2.476		
Sensitivity error	ϵ_G	%	-0.7	0.5	0.7	$R_L > 500\text{ k}\Omega$
Temperature coefficient of G	TCG	ppm/K			±100	-40°C ...105°C
Linearity error	ϵ_L	%		0.4	1.3	
Check current	I_{CK}	mA		100		10%
Output voltage(Check function)	V_{CK}	V		VOS+0.25		
Check enable voltage	V_{CE}	V	3.3		V_C	
Check disabled voltage	V_{CD}	V		< 0.2		
Reaction time @ 10 % of I_{PRN}	t_{ra}	μs		5		$R_L > 500\text{ k}\Omega$, $di/dt > 5\text{ A}/\mu\text{s}$
Step response time to 90 % of I_{PN}	t_r	μs		40		$R_L > 500\text{ k}\Omega$
Frequency bandwidth (-3dB)	BW	kHz		15		$R_L > 500\text{ k}\Omega$
Noise(1 Hz ~ 10 kHz)	V_{no}	mV rms		10		
Accuracy@ I_{PN} @TA = 25°C	$X_{25^\circ\text{C}}$	% of I_{PN}		±1.9		
Accuracy@ I_{PN} @TA = 105°C	$X_{105^\circ\text{C}}$	% of I_{PN}		±3.2		

19. Electrical data: SFG-1.0P/P2

At $T_A = 25\text{ }^\circ\text{C}$, $V_C = 5\text{ V}$.

Parameters	Symbol	Unit	Min	Typ	Max	Remark
Primary nominal residual rms current	I_{PN}	A	-1.02		1.02	
Primary residual current, measuring range	I_{PM}	A	-1.7		1.7	
Supply voltage	V_C	V	4.75	5	5.25	
Current consumption	I_C	mA		17.5	21.6	$I_P(\text{mA}) / N_a$ $N_a = 1000$ turns - $40\text{ }^\circ\text{C} \dots 105\text{ }^\circ\text{C}$
Output voltage referred to V_{ref} (Test current)	V_{out}	V	0.2	0.35	0.5	
Reference voltage @ $I_P = 0$	V_{ref}	V	2.495	2.5	2.505	Internal reference
External reference voltage	V_{REF}	V	2.3		4	Internal reference of V_{ref} input = $499\ \Omega$
Electrical offset current referred to primary	I_{OE}	mA	-24	7	24	
Temperature coefficient of VOE @ $I_P = 0$	TCV_{OE}	ppm/K		± 50	± 570	ppm/K of 2.5 V - $40 \dots 105\text{ }^\circ\text{C}$
Theoretical sensitivity	G_{th}	V/A		1.17		
Sensitivity error	ϵ_G	%	-1.6	0.5	1.6	$R_L > 500\text{ k}\Omega$
Temperature coefficient of G	TCG	ppm/K		± 400		- $40\text{ }^\circ\text{C} \dots 105\text{ }^\circ\text{C}$
Linearity error	ϵ_L	%		0.5	1	
Check current	I_{CK}	mA		170		10%
Output voltage(Check function)	V_{CK}	V		$V_{OS}+0.2$		
Check enable voltage	V_{CE}	V	3.3		V_C	
Check disabled voltage	V_{CD}	V		< 0.2		
Reaction time @ 10 % of I_{PRN}	t_{ra}	μs		7		$R_L > 500\text{ k}\Omega$, $di/dt > 5\text{ A}/\mu\text{s}$
Step response time to 90 % of I_{PN}	t_r	μs		50		$R_L > 500\text{ k}\Omega$, $di/dt > 5\text{ A}/\mu\text{s}$
Frequency bandwidth (-3dB)	BW	kHz		15		$R_L > 500\text{ k}\Omega$
Noise(1 Hz ~ 10 kHz)	V_{no}	mV rms		10		$R_L > 500\text{ k}\Omega$
Accuracy@ I_{PN} @ $T_A = 25\text{ }^\circ\text{C}$	X_{25c}	% of I_{PN}		± 1.9		
Accuracy@ I_{PN} @ $T_A = 105\text{ }^\circ\text{C}$	X_{105c}	% of I_{PN}		± 3.2		

20. Electrical data: SFG-1.5P/P2

At $T_A = 25\text{ }^\circ\text{C}$, $V_C = 5\text{ V}$.

Parameters	Symbol	Unit	Min	Typ	Max	Remark
Primary nominal residual rms current	I_{PN}	A		1.5		
Primary residual current, measuring range	I_{PM}	A	-2		2	
Supply voltage	V_C	V	4.75	5	5.5	
Current consumption	I_C	mA		17.5	21.6	$I_P(\text{mA}) / N_a$ $N_a = 1000$ turns - 40°C ... 105°C
Output voltage referred to V_{ref} (Test current)	V_{out}	V	0.12		0.5	
Reference voltage @ $I_P = 0$	V_{ref}	V	2.495	2.5	2.505	Internal reference
External reference voltage	V_{REF}	V	2.3		4	Internal reference of V_{ref} input = 499Ω
Electrical offset current referred to primary	I_{OE}	mA	-30	4.2	30	
Temperature coefficient of VOE @ $I_P = 0$	TCV_{OE}	ppm/K			±570	ppm/K of 2.5 V -40 ... 105 °C
Theoretical sensitivity	G_{th}	V/A		0.8		
Sensitivity error	ϵ_G	%	-1.6	0.5	1.6	$R_L > 500\text{ k}\Omega$
Temperature coefficient of G	TCG	ppm/K			±400	- 40°C ... 105°C
Linearity error	ϵ_L	%		0.5	1	
Check current	I_{CK}	mA		100		10%
Output voltage(Check function)	V_{CK}	V		VOS+0.08		
Check enable voltage	V_{CE}	V	3.3		V_C	
Check disabled voltage	V_{CD}	V		< 0.2		
Reaction time @ 10 % of I_{PRN}	t_{ra}	μs		5		$R_L > 500\text{ k}\Omega$, $di/dt > 5\text{ A}/\mu\text{s}$
Step response time to 90 % of I_{PN}	t_r	μs		50		$R_L > 500\text{ k}\Omega$, $di/dt > 5\text{ A}/\mu\text{s}$
Frequency bandwidth (-3dB)	BW	kHz		15		$R_L > 500\text{ k}\Omega$
Noise(1 Hz ~ 10 kHz)	V_{no}	mV rms		10		$R_L > 500\text{ k}\Omega$
Accuracy@ I_{PN} @TA = 25°C	$X_{25^\circ\text{C}}$	% of I_{PN}		±1.9		
Accuracy@ I_{PN} @TA = 105°C	$X_{105^\circ\text{C}}$	% of I_{PN}		±3.2		

21. Electrical data: SFG-2.0P/P2

At $T_A = 25\text{ }^\circ\text{C}$, $V_C = 5\text{ V}$.

Parameters	Symbol	Unit	Min	Typ	Max	Remark
Primary nominal residual rms current	I_{PN}	A		2		
Primary residual current, measuring range	I_{PM}	A	-3		3	
Supply voltage	V_C	V	4.75	5	5.5	
Current consumption	I_C	mA		17.5	21.6	$I_P(\text{mA}) / N_a$ $N_a = 1000$ turns - $40\text{ }^\circ\text{C} \dots 105\text{ }^\circ\text{C}$
Reference voltage @ $I_P = 0$	V_{ref}	V	2.495	2.5	2.505	Internal reference
External reference voltage	V_{REF}	V	2.3		4	Internal reference of V_{ref} input = $499\ \Omega$
Electrical offset current referred to primary	I_{OE}	mA	-24	7	24	
Temperature coefficient of V_{OE} @ $I_P = 0$	TCV_{OE}	ppm/K			570	ppm/K of 2.5 V - $40 \dots 105\text{ }^\circ\text{C}$
Theoretical sensitivity	G_{th}	V/A		0.66		
Sensitivity error	ϵ_G	%	-1.6	0.5	1.6	$R_L > 500\text{ k}\Omega$
Temperature coefficient of G	TCG	ppm/K		± 400		- $40\text{ }^\circ\text{C} \dots 105\text{ }^\circ\text{C}$
Linearity error	ϵ_L	%		0.5	1	
Check current	I_{CK}	mA		100		10%
Output voltage(Check function)	V_{CK}	V		$V_{OS} + 0.066$		
Check enable voltage	V_{CE}	V	3.3		V_C	
Check disabled voltage	V_{CD}	V		< 0.2		
Reaction time @ 10 % of I_{PRN}	t_{ra}	μs		5		$R_L > 500\text{ k}\Omega$, $di/dt > 5\text{ A}/\mu\text{s}$
Step response time to 90 % of I_{PN}	t_r	μs		40		$R_L > 500\text{ k}\Omega$
Frequency bandwidth (-3dB)	BW	kHz		15		$R_L > 500\text{ k}\Omega$
Noise(1 Hz ~ 10 kHz)	V_{no}	mV rms		10		
Accuracy@ I_{PN} @ $T_A = 25\text{ }^\circ\text{C}$	$X_{25^\circ\text{C}}$	% of I_{PN}		± 1.9		
Accuracy@ I_{PN} @ $T_A = 105\text{ }^\circ\text{C}$	$X_{105^\circ\text{C}}$	% of I_{PN}		± 3.2		

22. Electrical data: SFG-3.0P/P2

At $T_A = 25\text{ }^\circ\text{C}$, $V_C = 5\text{ V}$.

Parameters	Symbol	Unit	Min	Typ	Max	Remark
Primary nominal residual rms current	I_{PN}	A		3		
Primary residual current, measuring range	I_{PM}	A	-5		5	
Supply voltage	V_C	V	4.75	5	5.5	
Current consumption	I_C	mA		17.5	21.6	$I_P(\text{mA}) / N_a$ $N_a = 1000$ turns - $40\text{ }^\circ\text{C} \dots 105\text{ }^\circ\text{C}$
Reference voltage @ $I_P = 0$	V_{ref}	V	2.495	2.5	2.505	Internal reference
External reference voltage	V_{REF}	V	2.3		4	Internal reference of V_{ref} input = $499\ \Omega$
Electrical offset current referred to primary	I_{OE}	mA	-24	7	24	
Temperature coefficient of VOE @ $I_P = 0$	TCV_{OE}	ppm/K			570	ppm/K of 2.5 V - $40 \dots 105\text{ }^\circ\text{C}$
Theoretical sensitivity	G_{th}	V/A		0.4		
Sensitivity error	ϵ_G	%	-1.6	0.5	1.6	$R_L > 500\text{ k}\Omega$
Temperature coefficient of G	TCG	ppm/K		± 400		- $40\text{ }^\circ\text{C} \dots 105\text{ }^\circ\text{C}$
Linearity error	ϵ_L	%		0.5	1	
Check current	I_{CK}	mA		100		10%
Output voltage(Check function)	V_{CK}	V		$V_{OS}+0.04$		
Check enable voltage	V_{CE}	V	3.3		V_C	
Check disabled voltage	V_{CD}	V		< 0.2		
Reaction time @ 10 % of I_{PRN}	t_{ra}	μs		5		$R_L > 500\text{ k}\Omega$, $di/dt > 5\text{ A}/\mu\text{s}$
Step response time to 90 % of I_{PN}	t_r	μs		40		$R_L > 500\text{ k}\Omega$
Frequency bandwidth (-3dB)	BW	kHz		15		$R_L > 500\text{ k}\Omega$
Noise(1 Hz ~ 10 kHz)	V_{no}	mV rms		10		
Accuracy@ I_{PN} @ $T_A = 25\text{ }^\circ\text{C}$	X_{25c}	% of I_{PN}		± 1.9		
Accuracy@ I_{PN} @ $T_A = 105\text{ }^\circ\text{C}$	X_{105c}	% of I_{PN}		± 3.2		

23. Connection

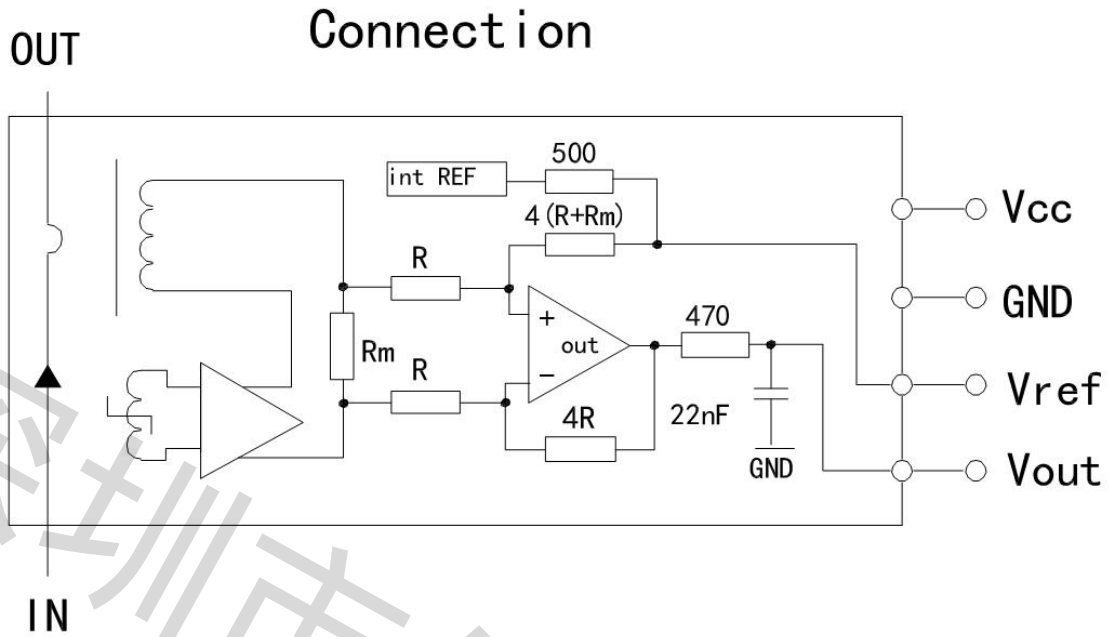

24. SFG- P/N PCB footprint

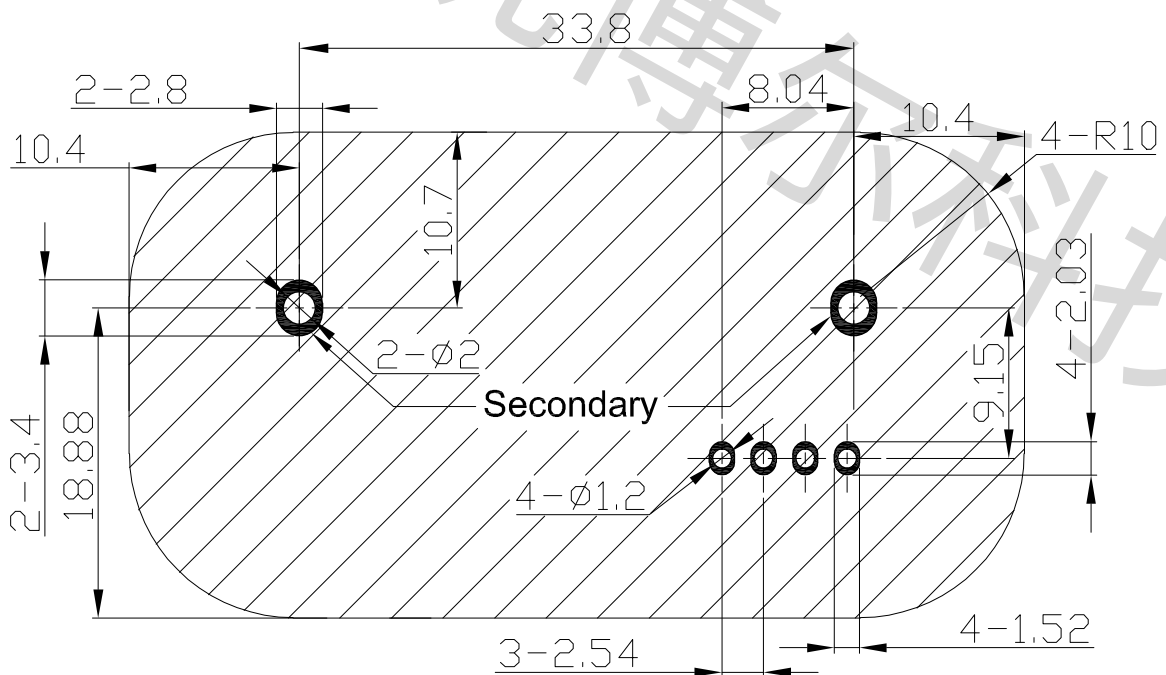

Assembly on PCB

- No Primary in shadow area
- Maximum PCB thickness 2.4 mm
- Wave-soldering: 260°C @ 10 s
- Recommended PCB hole diameter 1.2 mm for secondary pin.

26. SFG- P/P2 PCB footprint

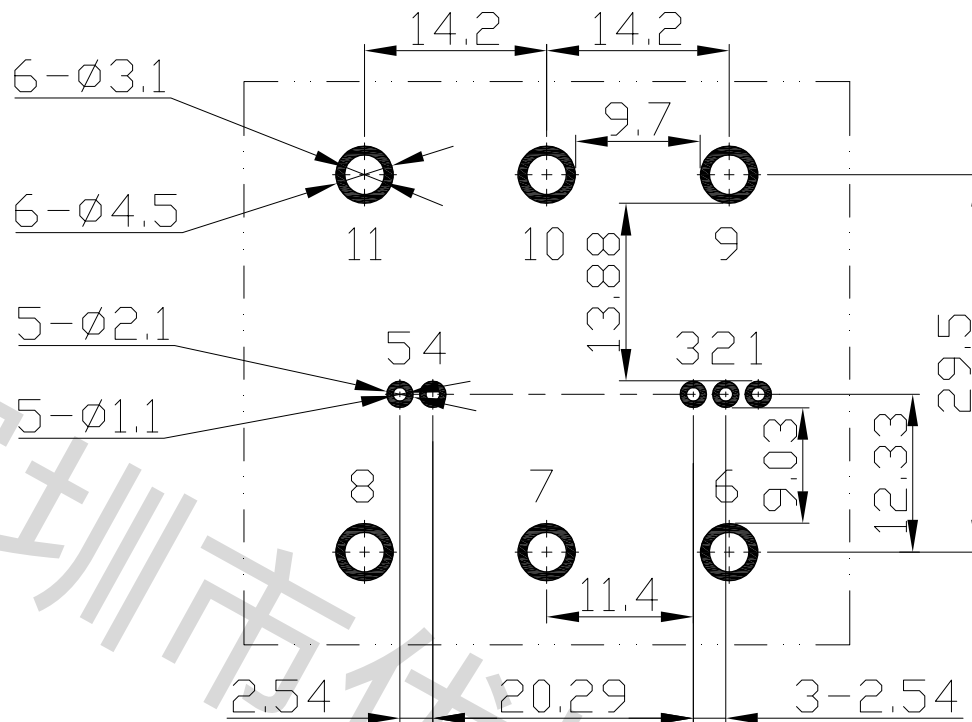

Assembly on PCB

- Maximum PCB thickness 2.4 mm
- Wave-soldering: 260°C @ 10 s
- Recommended PCB hole diameter 1.2 mm for secondary pin.

27. SFG- P/N Dimensions

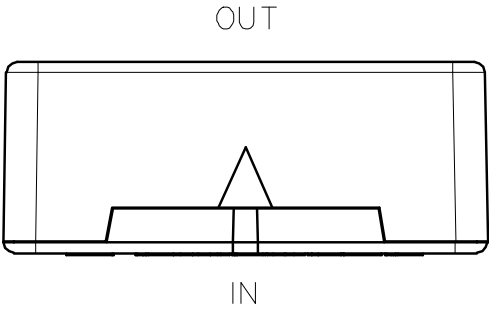

Terminals:

1	2	3
Vcc	GND	Vref
4	5	6
Vout	NC	NC

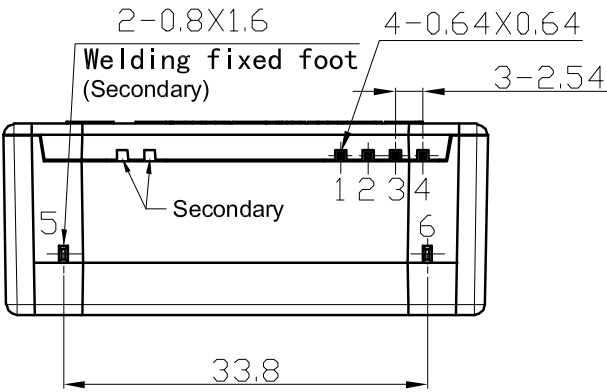
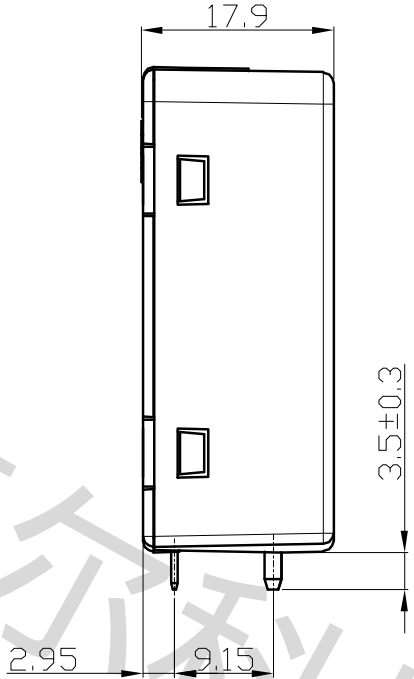
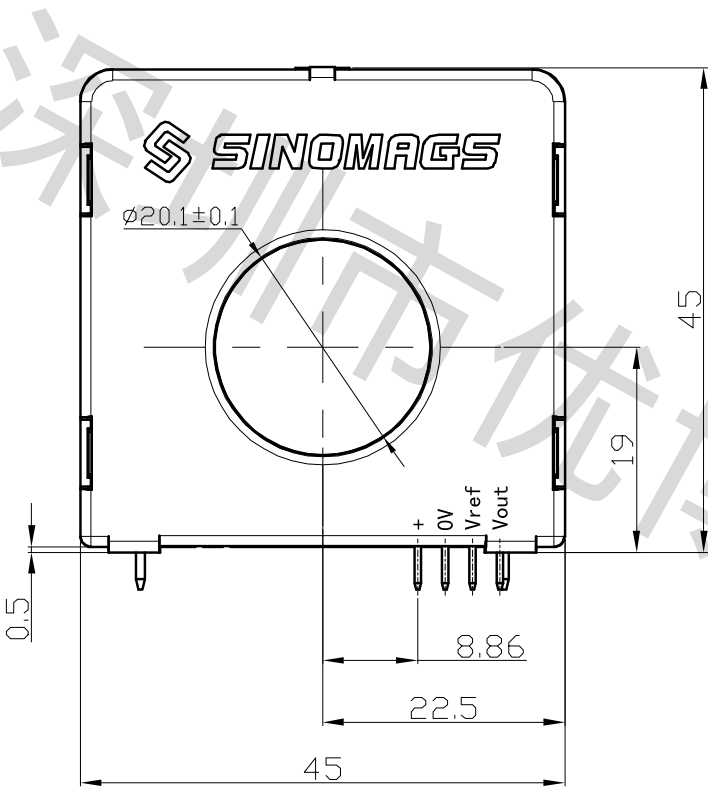

Material : Fit UL94V-0 & RoHS requirements ;
 General tolerance : ± 0.5
 Unit : mm

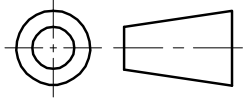

Assembly on PCB:

- 1、Maximum PCB thickness: 2.4mm;
- 2、Wave soldering profile No Pd process only: maximum 260°C, 10S;

28. SFG- P/P1 Dimensions

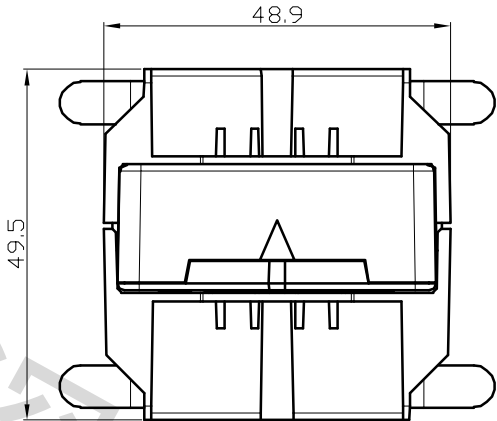

Terminals:

1	2	3
Vcc	GND	Vref
4	5	6
Vout	Test Out	Test In
7	8	9
I _{p+}	I _{p+}	I _{p+}
10	11	12
I _{p-}	I _{p-}	I _{p-}

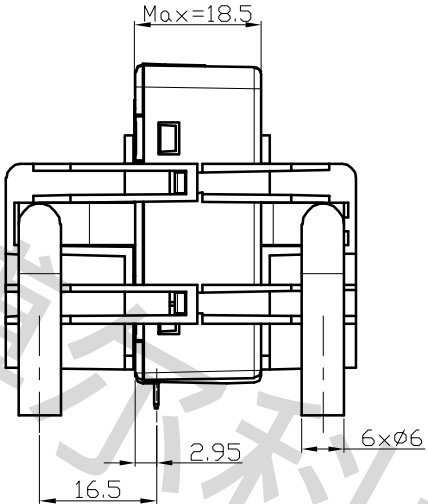
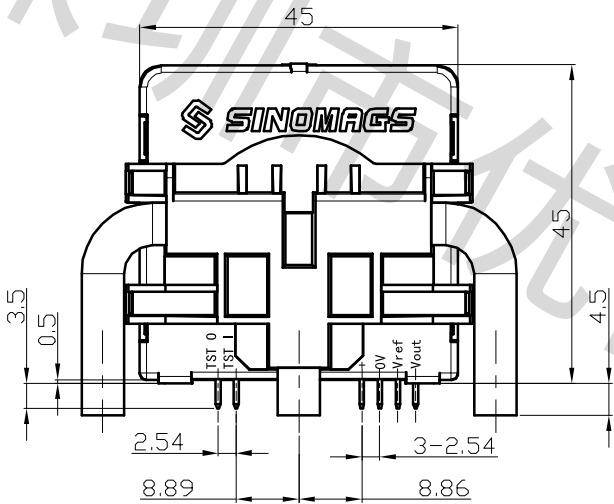

	d _{CI}	d _{CP}
A-B	15.3mm	---
A-C	9.4mm	12.9mm
C-D	16.0mm	16.0mm

D is secondary inside the transducer

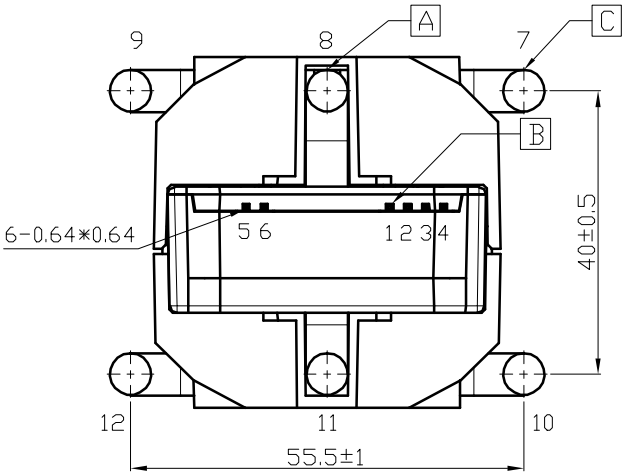

On the customer's PCBA		
	d _{CI}	d _{CP}
A-B	12.4mm	12.4mm
A-C	9.4mm	17.05mm

Material : Fit UL94V-0 & RoHS requirements ;
 General tolerance : ±0.5
 Unit :mm

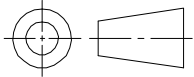

29. SFG- P/P2 Dimensions

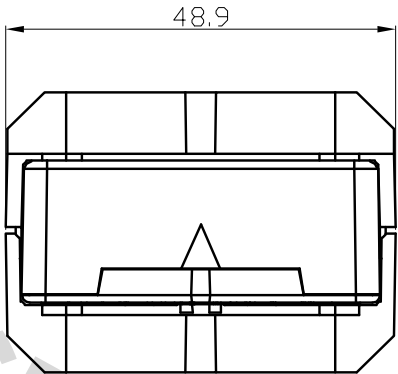

	D _{CI}	D _{CP}
B-C	10.6	13.3
A-C	11.4	15.8
C-D	--	15

D is secondary inside the transducer

On the customer's PCBA		
	D _{CI}	D _{CP}
B-C	9	9
A-C	9.7	9.7

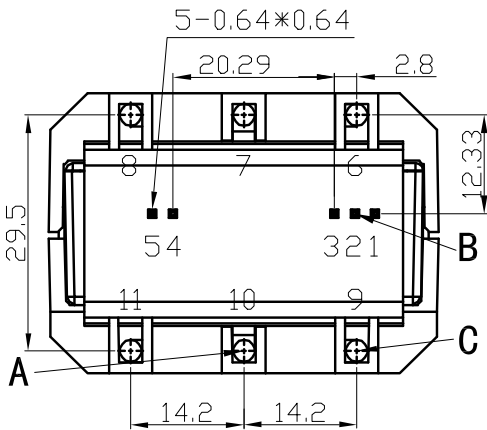
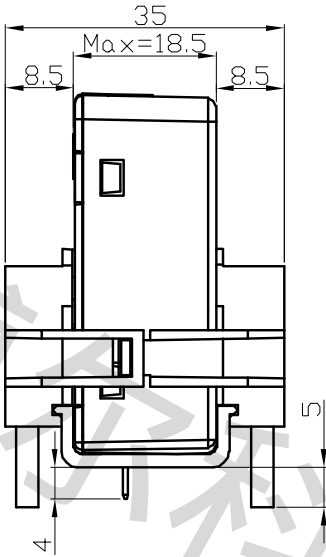
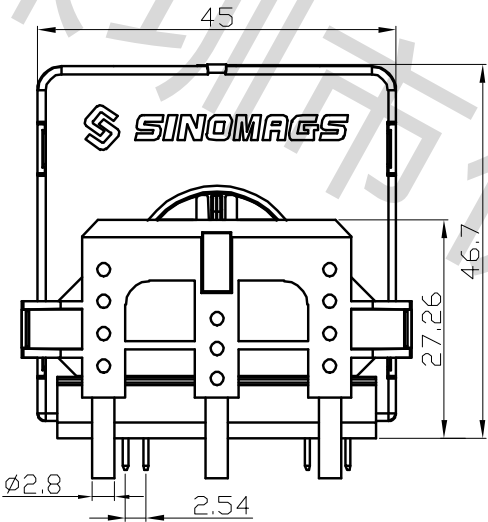

Terminals:

1	Vout
2	CHK
3	GND
4	Vcc
5	Vref
6	I _{p+}
7	I _{p+}
8	I _{p+}
9	I _{p-}
10	I _{p-}
11	I _{p-}

Material : Fit UL94V-0 & RoHS requirements ;

General tolerance : ±0.5

Unit : mm

